

# Sound waves of classical music optimize the performance of hydroponic lettuce cultivation

Frida Pardo Salazar, Bachiller<sup>1</sup>, Axl Mauricio Benavente, Bachiller<sup>2</sup>, Rita Cabello Torres, Magister<sup>3</sup>, Lorgio Valdiviezo-Gonzales, Doctor<sup>4</sup>

<sup>1-3</sup> Universidad César Vallejo, Escuela de Ingeniería Ambiental, Perú, amauriciob@ucvvirtual.edu.pe, fpardos@ucvvirtual.edu.pe, rcabellot@hotmail.com

<sup>4</sup>Universidad Tecnológica del Perú, Perú, lvaldiviez@utp.edu.pe

**Abstract**– *It is proposed to evaluate the impact of the application of musical sound waves on the development of lettuce crops through domestic hydroponics. For this purpose, an experimental method was applied to 36 units of common lettuce crops, half were exposed to classical music with 70 dB and the other half were exposed to environmental noise. Subsequently, the size, weight and growth time of the crop were measured. The results recorded that the exposure of lettuce to classical music achieved greater development (growth of 31.90 cm) at 30 days, unlike lettuces with exposure to environmental noise (growth of 29.90 cm) at 38 days. Likewise, the weight of the cultures exposed to classical music exceeded those of the cultures exposed to environmental noise by 98.34 g. Sound waves generated a positive effect on the development of lettuce crops. In this sense, it is recommended to apply sound waves to other types of crops to determine the most appropriate frequency for the maximum development of each crop.*

**Keywords**– *Domestic hydroponics, sound waves, environmental noise, decibels, classical music.*

## I. INTRODUCTION

One of the great current challenges is to satisfy the demand for food, given the growing world population by 2050, 9 million inhabitants are expected [1]. According to [2], the disadvantages of the use of agricultural lands are negative ecological problems that have economic and social repercussions, weaken the soils, and increase the risk of contamination of sources in water bodies with fertilizers.

Agricultural production brings with it negative impacts on the environment, and together with other production sectors, contributes to global warming. Hydroponics has been introduced around the world as a sustainable and efficient method for resource conservation and innovative agriculture. The system achieves environmental compliance with significant savings in water and fertilizer, minimal discharge of remaining fertilizer solution to the environment, and no discharge of contaminated wastewater, it is economically and environmentally efficient [3].

On the other hand, music therapy defines the therapeutic use of music to improve the health of a patient and has extended to the agricultural sector, with excellent results, it contributes to the growth of plants by exposing them to relaxing music; contrary to slow growth when exposed to noise [4]. For his part,

[5] highlights that classical music and rhythmic rock are considered positive music, and the negative effect of non-rhythmic traffic noise and rock music is considered negative music, although both contribute to the growth of plants. [6], indicate that the growth, development, and genetic characteristics of plants are strongly influenced by various environmental factors; however, the mechanisms by which the stimulation of sound waves affects the growth and development of plants are still unclear.

Therefore, plants develop an ability to receive sound waves, the application in a hydroponic system could improve the quality of the plants and reduce the time it usually takes for plants to grow. Given this lack of knowledge, the question arises: What is the impact of the application of musical sound waves on the development of lettuce crops through a domestic hydroponic system?

Reference [7], mentions that hydroponics is a method of plant care that allows them to be grown without soil, this is how herbs have been grown in large cities, plant maintenance is achieved with limited resources in a controlled environment. Reference [8] points out the benefits of reducing the healthy harvest time since chemicals are not applied for maintenance.

There are different types of hydroponic farming, such as deep-water culture (DWC), where plant roots are suspended directly in a nutrient-rich water solution; another is the nutrient film technique (NFT) which uses shallow channels. deep to circulate a nutrient solution to the roots of the plants through recirculation [9].

There is also the ebb and flow system (Flood and Drain) in which the growing system is flooded with a nutrient solution that is recirculated by a pump at intervals set by a timer. On the other hand, the wick system does not require a pump or timer; while another system called "drip" uses micro emitters to obtain nutrients and the water flows directly to the roots of the plant with the help of a pump [9]. These hydroponic systems generate significant water savings, lower energy consumption, and pesticides without depending on the soil resources [10].

Reference [11], mentions that hydroponics has important advantages in the efficient use of resources, in the reuse of water, reduces drainage by up to 80%, concentrates the rest of the nutrients, avoids pollution of water courses, rivers, salinization, and environmental degradation. Reference [12]

highlighted the simplicity of the systems and the level of plant growth much higher than that achieved in agricultural soils.

This type of plant cultivation can generate shade in homes by reducing solar radiation and improving the quality of life of people and the environment [13]. On the other hand, the emission of waves allows efficient growth of plants; for the industry, this would greatly help the mass production of crops that produce more oxygen, thus reducing global warming and pollution [14].

The fact is that the particles of the medium vibrate in the same direction as the direction of wave propagation. The function and can refer to the variation of pressure [15], its application not only contributes to agricultural production, generating economic improvements in the agricultural sector and making it environmentally sustainable [4].

Plants can absorb significant amounts of acoustic energy, especially when there is soil substrate, which plays an important role in sound absorption, substrates absorb up to 80% of the incident acoustic energy at frequencies above 1000 Hz and plants absorb throughout the tested frequency range [16]. In this way, the particles of the medium oscillate in the same direction of wave propagation, and the function can be related to the change in pressure of the medium causing the longitudinal displacement of the waves.

Reference [17], mentions that under optimal stimulation conditions (100 dB and 800 Hz), the sound field promotes plant growth and moderate stimulation improves the assimilation of tissues and cells, improves physiological activity and promotes plant growth. On the other hand, Reference [18] suggests musical vibrations between 90 and 130 decibels to achieve a positive effect; even harmonious levels of 70 decibels, combined with good lighting, also achieve good results.

Likewise, comparative tests have been carried out using different types of electronic music, rock music and classical music, these contributed to the growth of lettuce, the yield of edible parts was increased, the chlorophyll content in lettuce leaves and photosynthesis were promoted [19].

Sound waves have been applied for the growth of a variety of plants. Reference [20], cultivated mung bean stimulated for 72 h with audible tones at 1000-1500 Hz, 1500-2000 Hz and 2000-2500 Hz and intensities [80 dB(A), 90 dB(A), 100 dB(A)], the growth of mung beans was favored due to the regularity of the sound fields. Reference [21], grew water spinach (*Ipomoea Aquatica*) using Plant Harmless Technology (PAFT) and a hydroponic system with electronic, classical and rock music in soil and under non-immersion and flooding conditions.

The results showed a significant increase in diameter average root surface, root surface and total root length. The hydroponic system increased spinach biomass in water from 28.27% to 38.32% and in soil between 43.75% and 63.75% without water stress.

## II. METHODOLOGY

The experimental design was made up of 36 experimental units (lettuce) divided into two systems, the first consisting of 18

units of lettuce was grown in a conventional hydroponic system and the second in a hydroponic system with sound waves. To develop the design of the NFT hydroponic systems, the AutoCAD program was used.

The systems were separated, the first exposed to noise due to its location in an industrial area with high ambient noise and the second system was separated from the first and exposed to classical music, both with the same surface area of 6 m<sup>2</sup>. The hydroponic systems were built with PVC pipes and were joined at each corner to generate recirculation of the nutrient solution and activate- feed the roots of the cultivated vegetables. The design is seen in the following diagram:

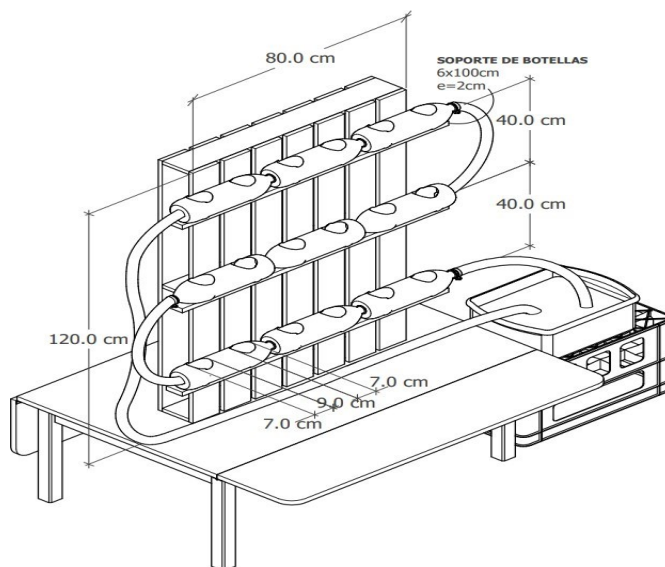

Fig. 1 Hydroponic system design

Peat (75%) and perlite (25%) were used as a substrate. Additionally, a nutrient solution composed of sulfur, iron, molybdenum, manganese, boron, zinc, copper and nickel salts was used. Considering that plants as living beings feel the vibrations of music, it has been reported that sounds close to 100 decibels in their environment produce positive effects [22]. However, it was decided to apply a maximum of 70 dB of varied classical music for 24 hours a day. For this, the seeds were preliminarily germinated in the substrates (3-4 seeds per experimental unit) and then transplanted in the NFT systems, this was possible without the seeds having contact with sunlight for 7 days under permanent daily irrigation. Subsequently, they were subjected to sunlight and irrigation with the nutrient solution for two weeks. Once germinated, they were placed individually in a seedbed so that the roots could develop [3].

Various aromatic plants (rosemary, basil, and wormwood) were used to control pests; these act by reducing the phytophagous actions of lepidopteran larvae in the crop [23]. Sound waves can also improve the immune system of plants. For example, [24]. Red mites on greenhouse tomatoes, aphids,

gray mold, late blight, and viral diseases were reduced by 6-11%, and rice hull mites decreased by 50%.

The measurement parameters considered were: cultivation or growth time (days), weight (g), and size (cm) of the lettuce.

Likewise, the average sound levels in the plants subjected to classical music ranged between 59.43 and 50.22 dB respectively. Descriptive statistics were applied, using the Microsoft Excel program, which allowed the creation of figures and tables of the statistical results.

### III. RESULTS AND DISCUSSION

The sound waves of classical music and environmental noise reached average intensities of 59.43 and 50.22 Db respectively; while the lettuces were transplanted to hydroponic systems after 15 days of germination. Table 1 describes the statistical results of the maximum development times reached by lettuce in the two hydroponic experimental blocks; subjected to environmental noise and classical music respectively.

Each block had 18 experimental units and it was the culture with classical music that achieved greater development eight days before (time reduction: 21.7%) than the culture subjected to environmental noise, achieving its maximum development between 28 to 32 days. Regarding the weight obtained, it can be seen that classical music exceeded the weight achieved by the crop subjected to environmental noise by 50.4% ±6.5.

These results achieved a shorter crop development time compared to the 35 days reported by [25], who exposed the crop to environmental noise and potassium chloride levels. Sonic stimulation affects the metabolism of plants at the cellular level and increases the size and number of stomata on each leaf, which allows the absorption of water and nutrients from the soil, favoring rapid root growth and plant growth [26]. According to [4], plants grow even faster when they are exposed to pleasant music, however, when they are subjected to environmental noise their growth is usually slow.

TABLE I

STATISTICAL DESCRIPTION OF LETTUCE DEVELOPMENT TIMES IN THE TWO HYDROPONIC EXPERIMENTAL BLOCKS

Parameter	Min	Max	Mean	±Standard Deviation
Time (days)EN	36	40	38.2	1.1
Time (days)CM	28	32	32	1.2
Decrease in cultivation time (%)	-	-	21.66	1.7
Weigth(g)EN	90.5	110	100.4	5.2
Weigth (g)CM	169.4	250.9	207.8	22.7
Increase Weigth (%)	-	-	50.4	6.5

The Shapiro Wilk test ( $n \leq 50$ ) recorded p-values  $> 0.05$  between the two blocks of hydroponic crops subjected to environmental noise and classical music, indicating the normality of the data on development time, length, and weight

of the lettuce. The T-Student test (Table 2) produced a significant p-value ( $p < 0.05$ ) between the two hydroponic blocks demonstrating that the application of classical music sound waves accelerates the growth time of lettuce crops. That is, the Lettuce achieves greater length and weight in a shorter hydroponic growing time.

Various studies at certain audio frequencies facilitate germination and plant growth [27].

Reference [28], produced lettuce by reducing the use of nutrient solution by 50% compared to a conventional system in soil [29]. These closed hydroponic systems have important advantages because recirculation allows the reuse of nutrients in the water, reducing their use in the production process [30].

Our results also confirm that the automatic use of liquid flow is successful and comparable with the application of Arduino, speeding up crop growth [31]. The automatic application of NFT hydroponic systems is more agile than conventional systems with selenoid valves since it is difficult to maneuver the appropriate flow according to the age of the crop [32].

Regarding the weights (mean) reached by the lettuce crops with exposure to classical music and exposure to environmental noise, they were 207.8 g and 100.4g respectively (Table I).

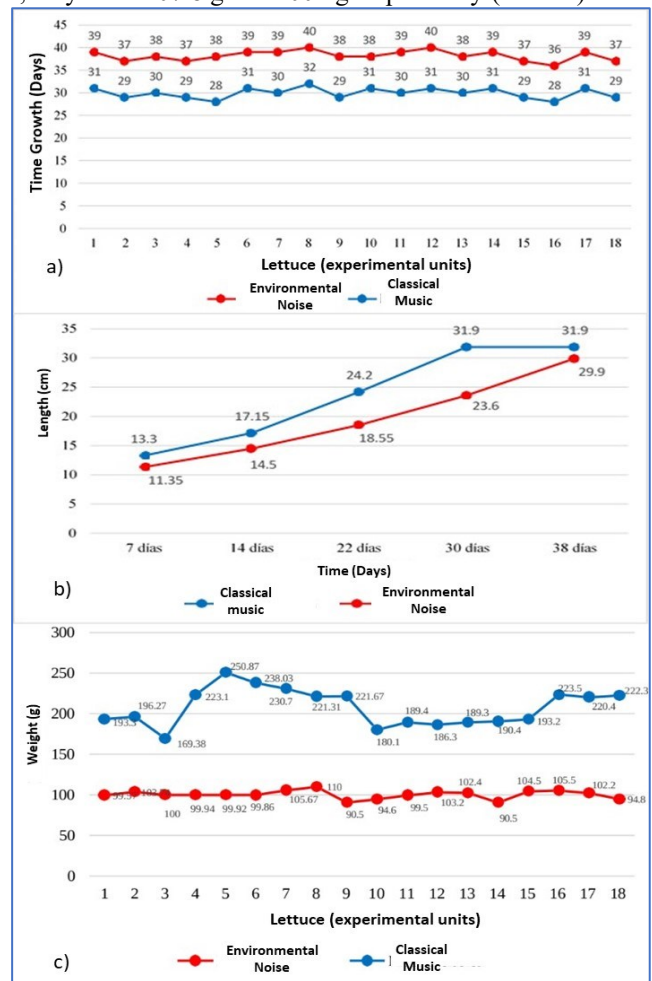

Fig 2. Development of hydroponic lettuce crops: a) growth time (days), b) length (cm) and c) weight (g)

Fig. 2 shows the development over time of the two hydroponic systems, Fig. 2a refers to the growth time, that is, the days of cultivation in which the lettuces were developed. Fig. 2b compares the lengths achieved and Fig. 2c compares the weights obtained in the cultivation period.

From these results it is evident that lettuce crops with exposure to classical music exceed the weights of crops with exposure to environmental noise by 98.34 g (48.86%). These results were higher than those reported by [33], who achieved weights of up to 150.1 g for lettuce grown hydroponically without music, and [34], who similarly obtained a weight of 115.45 g for the same species. [35] managed to increase the weight of three species of lettuce by 44.1% without applying music, [36], argues that in addition to the increase in the content of indoleacetic acid (IAA), polyamine compounds (PAS) also increase, this leads to the division of plant cells and the formation of leaves, increasing their weight.

On the other hand, experiments without the application of sounds achieve weights lower than those achieved in this research, weights of 70.74 to 112.63g have been reported 30 days after the transplant was carried out using a NFT hydroponic installation [37]; [38].

Reference [34] also evaluated variables such as plant height, root length, and weight and found that all lettuce varieties such as Curly Green (crespa lettuce) had significant differences in productive activities. This variety had the best performance with an average fresh weight of 203.36 g. Furthermore, reference [14], applied a different method to the NFT system, this system was the Floating Root system, achieving weights of 115.8 to 150.1 g of plants. All this indicates that there is a better effect and a great difference between both systems, although the season of the year plays an important role in the crops.

Table II, shows the statistical differences found between the crops related to the rapid development time, length and weight of the lettuces.

TABLE II  
LETTUCE CROP DEVELOPMENT T-STUDENT TEST

Parameter	Mean	Standard Deviation	Standard Error (mean)	CI/(95%) Lower	CI/(95%) Upper	t	df	Sig. (bilateral)
Time (days)	827.8	0.7	0.2	-861.0	-794.5	52.5	17	0
Length (cm)	4.7	2.8	1.4	0.2	9.2	3.3	3	0.044
Weight (g)	107.4	22.6	5.3	96.2	118.6	20.2	17	0

Table III presents the results of progressive growth at 7, 14, 22, 30 and 38 days. It produced a maximum value of 31.90 cm

in length for lettuce subjected to classical music in 30 days versus environmental noise (average length: 29.90 cm) at 38 days. It is also important to highlight those cases have been reported in which NFT hydroponic lettuce crops were not subjected to any sound or noise; [38] reported average heights of 16.97 cm 30 days after transplant. This value is lower than that reported in this study (Table 3) for crops exposed to environmental noise (23.6 cm) and classical music (Maximum length: 31.9 cm).

TABLE III  
LETTUCE LENGTH IN HYDROPONIC EXPERIMENTS

Growth time (days)	Length (cm)EN			Length (cm)CM			Growth Increase (EN-CM)	
	Min (cm)	Max (Max)	Mean (cm)	Min (cm)	Max (Max)	Mean (cm)	cm	%
7	11.1	11.6	11.35	13.1	14.2	13.65	0.85	7.04
14	13.1	15.9	14.5	16.1	18.2	17.15	2.35	13.7
22	17.1	20	18.55	23.1	25.3	24.2	4.05	16.73
30	22.6	24.6	23.6	30.2	33.6	31.9	8.3	26.02
38	29.2	30.6	29.9	30.2	33.6	31.9	2	6.27

This maximum length corresponded to an average sound pressure application of 59.43 dB; while the crop subjected to environmental noise the average sound pressure was 50.22 dB.

Treatments with classical music improved crop growth by 2cm (6.27%), however, this value is lower than that reported by [21], who applied sound pressure of 80 dB to hydroponic spinach (*Ipomoea*) crops, achieving between 13 and 18.5% increase in length. Reference [39] previously demonstrated that Mozart's music increased the length of his plants.

The molecules are initially static, at rest, but then move harmoniously, being beneficial for the activation of plant cells [21]. Reference [40] investigated the growth of mung bean (*Vania radiata*) subjected to 5 acoustic patterns (soprano, classical, nature, rock, and chronic recitation) at a sound pressure level of 60 dB ± 10 dB, in which they showed that these acoustic patterns promoted growth in different parts of the mung bean.

This situation demonstrates that acoustic frequency could stimulate plant IAI secretion and plant growth [41]; [42]; as long as it does not reach noise levels which generates negative effects on plants [27]. The Fig. 3–5, show the process applied in the experiment:



Fig. 2. Preparation of the germination process of Lettuce Seeds



Fig. 3. NFT hydroponic system

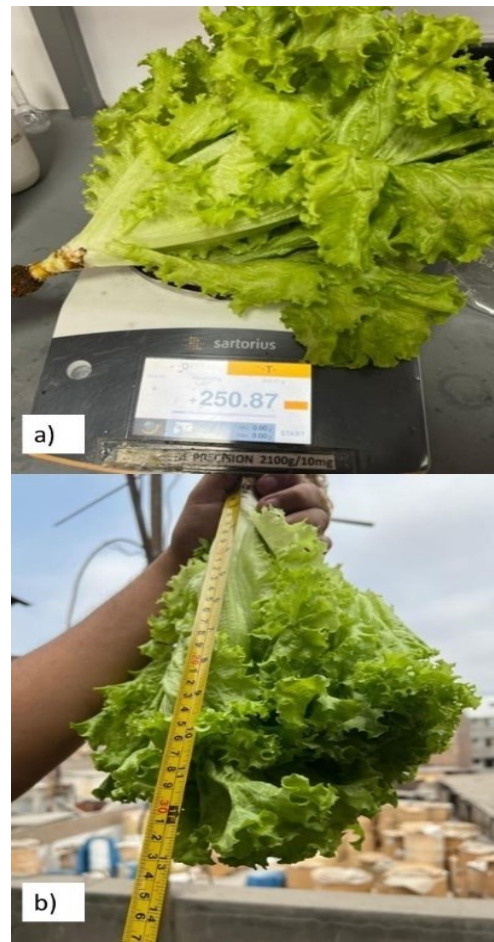

Fig 4. Measuring the lettuce: a) Weight (g and b) Length (cm)

#### IV. CONCLUSIONS

The application of classical music sound waves in domestic hydroponic cultivation accelerated the development time of lettuce crops, reaching their final size 30 days after being transplanted to the NFT system, unlike the system exposed to environmental noise.

The hydroponic culture subjected to environmental noise reached a final size after 38 days, because the sound stimulation affected the metabolism of the plants at the cellular level, despite the increase in height and the number of stomata on each leaf. It was shown that the application of harmonious sound waves allowed the absorption of water and nutrients from the soil, thus promoting rapid growth of roots and plants.

The music provided the vibration of sound waves of a certain frequency, causing them to resonate in the cells, the lettuce molecules moved harmoniously, which was beneficial for the activation of plant cells.

The application of sound waves with a level of 59.43 and 50.22 dB, applied to the cultivation system, increased the mass of the lettuce until reaching 250.87 g. On the other hand, the lettuce exposed to environmental noise only reached a maximum weight of 110 g.

This is because after sound stimulation, the content of indole acetic acid and polyamine compounds increases in plants, which caused the division of plant cells and the establishment of plant morphology, promoting the formation of leaves and the increase in plant weight.

#### ACKNOWLEDGMENT

The authors are grateful for the financial support of the Universidad Tecnológica del Peru.

#### REFERENCES

- [1] FAO, "Food, Nutrition and Agriculture - 1 - Food for the Future," 1991. [Online]. Available: <http://www.fao.org/docrep/u3550t/u3550t00.htm>.
- [2] A. García, M. Laurín, M. J. Llosá, V. González, M. J. Sanz, and J. L. Porcuna, "Contribución de la agricultura ecológica a la mitigación del cambio climático en comparación con la agricultura convencional," *Agroecología*, vol. 1, no. 0 SE-Artículos, pp. 75–88, Apr. 2008, [Online]. Available: <https://revistas.um.es/agroecologia/article/view/169>.
- [3] R. Pertierra Lazo, C. Torres, and C. Balmaseda Espinosa, "Inversión en sistemas hidropónicos: Análisis comparativo de materiales, escalas y sistemas," *Rev. Científica y Tecnológica UPSE*, vol. 6, no. 2 Dicbre., pp. 15–23, 2019, doi: 10.26423/rctu.v6i2.437.
- [4] M. Henríquez, M. Ramos, A. Da Silva, E. Siu, S. Elcoro, and Y. Acosta, "Efecto de la aplicación de dos tipos de música en el desarrollo de plantas de maíz (*Zea mays* L)," *Multiciencias*, vol. 10, no. Extraordinario, pp. 28–35, 2010.
- [5] R. Vanol, D., & Vaidya, "Effect of types of sound (music and noise) and varying frequency on growth of guar or cluster bean (*Cyamopsis tetragonoloba*) seed germination and growth of plants.," *Quest*, vol. 2(3), pp. 9-14., 2014.
- [6] I. Khait, U. Obolski, Y. Yovel, and L. Hadany, "Sound perception in plants," *Semin. Cell Dev. Biol.*, vol. 92, pp. 134–138, 2019, doi: <https://doi.org/10.1016/j.semcdb.2019.03.006>.
- [7] V. Albuja, J. Andrade, C. Lucano, and M. Rodriguez, "Comparison of the advantages of hydroponic systems as agricultural alternatives in urban areas," *Minerva*, vol. 2, no. 4 SE-Papers, pp. 45–54, Mar. 2021, doi: 10.47460/minerva.v2i4.26.
- [8] J. López, "La producción hidropónica de cultivos," *Idesia (chile)*, vol. 36, no. 2, pp. 139–141, 2018.
- [9] M. S. Gumisiriza, J. M. L. Kabirizi, M. Mugerwa, P. A. Ndakidemi, and E. R. Mbega, "Can soilless farming feed urban East Africa? An assessment of the benefits and challenges of hydroponics in Uganda and Tanzania," in *Environmental Challenges*, 2022, vol. 6, p. 100413, doi: <https://doi.org/10.1016/j.envc.2021.100413>.
- [10] S. Hosseinzadeh, Y. Verheust, G. Bonarrigo, and S. Van Hulle, "Closed hydroponic systems: operational parameters, root exudates occurrence and related water treatment," *Rev. Environ. Sci. Bio/Technology*, vol. 16, no. 1, pp. 59–79, 2017, doi: 10.1007/s11157-016-9418-6.
- [11] J. F. Velazquez, D. F. Morales, R. Roblero, and A. Aguilar, "Requerimientos Prácticos Para Implantar Una Fábrica De Plantas Casera ( Hpfal )," pp. 1–7, 2021.
- [12] R. Gashgari, K. Alharbi, K. Mughrbil, A. Jan, and A. Glolam, "Comparison between growing plants in hydroponic system and soil based system," in *Proceedings of the World Congress on Mechanical, Chemical, and Material Engineering*, 2018, pp. 1–7, doi: 10.11159/icmie18.131.
- [13] S. Zhang, Z. Chen, C. Cao, Y. Cui, and Y. Gao, "Photothermal-Management Agricultural Films toward Industrial Planting: Opportunities and Challenges," *Engineering*, 2023, doi: <https://doi.org/10.1016/j.eng.2023.06.016>.
- [14] R. P. Lazo and J. Q. Gonzabay, "Economic analysis of hydroponic lettuce under floating root system in semi-arid climate," *La Granja*, vol. 31, no. 1, pp. 118–130, Mar. 2020, doi: <https://doi.org/10.17163/lgr.n31.2020.09>.
- [15] S. Huang *et al.*, "The attenuation mechanism and regular of the acoustic wave on propagation path in farmland soil," *Comput. Electron. Agric.*, vol. 199, p. 107138, 2022, doi: <https://doi.org/10.1016/j.compag.2022.107138>.
- [16] F. Asdrubali, F. D'Alessandro, N. Mencarelli, and K. V. Horoshenkov, "Sound absorption properties of tropical plants for indoor applications," *21st Int. Congr. Sound Vib. 2014, ICSV 2014*, vol. 4, no. January, pp. 3249–3256, 2014.
- [17] V. Chivukula and S. Ramaswamy, "Effect of Different

- Types of Music on Rosa Chinensis Plants,” *Int. J. Environ. Sci. Dev.*, vol. 5, no. 5, pp. 431–434, 2014, doi: 10.7763/ijesd.2014.v5.522.
- [18] F. Del Stabile, V. Marsili, L. Forti, and L. Arru, “Is There a Role for Sound in Plants?,” *Plants*, vol. 11, no. 18, 2022, doi: 10.3390/plants11182391.
- [19] B. Cheng *et al.*, “Selenium nanomaterials improve the quality of lettuce (*Lactuca sativa* L.) by modulating root growth, nutrient availability, and photosynthesis,” *NanoImpact*, vol. 29, p. 100449, 2023, doi: <https://doi.org/10.1016/j.impact.2022.100449>.
- [20] W. Cai, H. He, S. Zhu, and N. Wang, “Biological Effect of Audible Sound Control on Mung Bean (*Vigna radiata*) Sprout,” *Biomed Res. Int.*, vol. 2014, p. 931740, 2014, doi: 10.1155/2014/931740.
- [21] S. Wang, Y. Shao, J. Duan, H. He, and Q. Xiao, “Effects of Sound Wave and Water Management on Growth and Cd Accumulation by Water Spinach (*Ipomoea aquatica* Forsk.),” *Agronomy*, vol. 12, no. 10, 2022, doi: 10.3390/agronomy12102257.
- [22] S. Y. Sharan, S. Goswami, P. K. Ghosh, L. K. Barik, and R. K. Saw, “A Novel Approach to Supplement Plant Growth with Devotional Music: An Experimental Research on Mung Bean (*Vigna radiata* L.) A Novel Approach to Supplement Plant Growth with Devotional Music: An Experimental,” *J. GEOINTERFACE*, vol. 2, no. 2, 2023.
- [23] A. Garcés, “Insecticidal effect of aromatic plants in combination with two types of biol on some pests of the corn crop,” *Manglar*, vol. 18, no. 4, pp. 381–388, 2021, doi: 10.17268/manglar.2021.049.
- [24] S. Wang and Q. Xiao, “Effect of Audio Control Technology on Lettuce Growth,” *Sustain.*, vol. 15, no. 3, 2023, doi: 10.3390/su15032776.
- [25] B. Ayala, C. Huanca, and C. Fernández, “Evaluación del cultivo de la lechuga (*Lactuca sativa*) en sistema hidropónico bajo dos niveles de cloruro de potasio,” *Rev. Investig. e Innovación Agropecu. y Recur. Nat.*, vol. 6, no. 2, pp. 66–71, 2019.
- [26] F. Arlius, R. E. Putri, N. S. Putri, and I. Putri, “Effect of acoustic waves on the growth and productivity of sawi plants (*Brassica Juncea* L.),” *IOP Conf. Ser. Earth Environ. Sci.*, vol. 757, no. 1, 2021, doi: 10.1088/1755-1315/757/1/012021.
- [27] R. Chowdhury and A. Gupta, “Effect of Music on Plants,” *Int. J. Sci. Res.*, vol. 12, no. 10, pp. 28–29, 2023, doi: 10.21275/sr23924093613.
- [28] L. I. Lara-Herrera, A; de la Rosa-Rodriguez, R; Trejo-Téllez, “Proporciones De Macronutrientes,” *Bioagro*, vol. 35, no. 2, pp. 113–122, 2023.
- [29] N. Gruda, M. Bisbis, and J. Tanny, “Impacts of protected vegetable cultivation on climate change and adaptation strategies for cleaner production – A review,” *J. Clean. Prod.*, vol. 225, pp. 324–339, 2019, doi: <https://doi.org/10.1016/j.jclepro.2019.03.295>.
- [30] J. E. Son, H. J. Kim, and T. I. Ahn, “Chapter 20 - Hydroponic systems,” T. Kozai, G. Niu, and M. B. T.-P. F. (Second E. Takagaki, Eds. Academic Press, 2020, pp. 273–283.
- [31] Iswanto, P. Megantoro, and A. Ma’arif, “Nutrient Film Technique for Automatic Hydroponic System Based on Arduino,” in *2020 2nd International Conference on Industrial Electrical and Electronics (ICIEE)*, 2020, pp. 84–86, doi: 10.1109/ICIEE49813.2020.9276920.
- [32] M. S. N. Kabir *et al.*, “Technological Trends and Engineering Issues on Vertical Farms: A Review,” *Horticulturae*, vol. 9, no. 11, 2023, doi: 10.3390/horticulturae9111229.
- [33] R. Pertierra and J. Quispe, “Economic Analisis of hidroponic lettuce floating root system in semi-arid climate,” *Rev. Ciencias la Vida*, vol. 31, no. 1, pp. 118–130, 2020, [Online]. Available: <http://doi.org/10.14163/Igr.n31.2020.09>.
- [34] S. T. Leiva Espinoza, A. Román Peña, N. C. Vilca Valqui, and J. C. Neri Chávez, “Comportamiento productivo de 11 variedades de lechuga (*Lactuca sativa* L.) en sistema hidropónico NFT recirculante (Chachapoyas – Amazonas),” *Rev. Investig. Agroproducción Sustentable*, vol. 2, no. 1, p. 50, 2019, doi: 10.25127/aps.20181.384.
- [35] R. . Hou, T.Z and Mooneyham, “Applied Studies of the Plant Meridian System II. Agri-wave Technology Increases the Yield and Quality of Spinach and Lettuce and Enhances the Disease Resistant Properties of Spinach,” *Am. J. Chin. Med.*, vol. 27, no. 2, pp. 131–141, 1999.
- [36] L. Chen, A. Figueredo, H. Villani, J. Michajluk, and M. Hungria, “Diversity and symbiotic effectiveness of rhizobia isolated from field-grown soybean nodules in Paraguay,” *Biol. Fertil. Soils*, vol. 35, no. 6, pp. 448–457, 2002, doi: 10.1007/s00374-002-0493-1.
- [37] A. Rodríguez-delfín, A. D. J. López-herrera, and V. Rojas-rojas, “Rendimiento de plantas de lechuga (*Lactuca sativa*) cultivadas con sistemas NFT modificados en tiempos de pandemia,” *Curr. Top.*

*Agron. Sci.*, vol. 2, pp. 1–9, 2021.

- [38] B. Frasetya, A. Taofik, and L. Nasrulloh, “The effectiveness of the application method of liquid organic fertilizer in different concentration on lettuce,” *IOP Conf. Ser. Earth Environ. Sci.*, vol. 694, no. 1, 2021, doi: 10.1088/1755-1315/694/1/012024.
- [39] I. Rojas, “La música y la estimulación temprana,” *Escena Rev. las artes*, vol. 65, no. 2, pp. 35–43, 2009.
- [40] N. A. H. Abdullah, K. A. Rani, M. H. F. Rahiman, and A. M. Noor, “The effect of acoustic exposure on the growth of mung beans (*vigna radiata*),” *Pertanika J. Sci. Technol.*, vol. 27, no. 3, pp. 1459–1470, 2019.
- [41] S. Vico, “Factores abióticos que afectan la biosíntesis de ácido indolacético en bacterias endófitas de maíz,” 2017.
- [42] Z. Junru, J. Shiren, and S. LianQing, “Effects of music acoustic frequency on indoleacetic acid in plants.,” *Agric. Sci. Technol. Hunan*, vol. 12, pp. 1749–1752, 2011, [Online]. Available: <https://api.semanticscholar.org/CorpusID:80721244>.